

**Universal Field Controller for motorized fire and smoke extraction dampers.
For bus (Modbus or BACnet) or analog integration into a superior system.
With separate phase for electronics (24 V AC/DC) and actuator power supply (24 V AC/DC...230 V AC).**

 **ATTENTION: 230 V Power Supply for Actuators**



Content

Section (continuation)	Page	Section (continuation)	Page
Technical Data	1	Thermoelectric Tripping Device - Connection	12
Cable Specification	4	Smoke Detectors – Connections	12
Dimensions	5	Conventional Application	13
Removing the Cover of the Housing	6	Electrical Installation for Conventional Application	14
Electrical Installation	7	Explanation of LEDs	15
Power Supply	8	Functionality of Test Buttons	16
Modbus and BACnet Addressing	9	Run Time Monitoring of Actuator	17
Configuration through Dip Switch	10	Full Auto Test Application	17
Connection Details	11	Bus Monitoring Application	18

Technical Data

 **ATTENTION: 230 V Power Supply for Actuators**

Electrical Data / FSC-UFC24-230, Control Unit	Nominal Voltage	24 V AC / DC
	Nominal Voltage Range	-20%... + 20%
	Dimensioning	2 VA
	Power Consumption	2 W
	Connections	Quick connections (terminals)
Electrical Data / Actuators	Nominal Voltage	24 V AC/DC - 230 V AC
	Nominal Voltage Range	Acc. to manufacturer specifications
	Dimensioning	Acc. to manufacturer specifications
	Power Consumption	Acc. to manufacturer specifications
	Connections	AMP plug in connections and quick connections (terminals)

Communication / Modbus



Protocol	Modbus RTU
Medium	RS-485, not electrically isolated
Transmission Formats	Specified by Modbus RTU Standards
Number of Devices per Line	100 (without repeater)
Baud Rates	9'600, 19'200, 38'400, 76'800 bps
Address	1..127 (0 reserved for broadcast)
Termination	120Ω line termination. Jumper available on extra pin on PCB. Position of jumper if FSC-UFC24-230 is last Modbus device in line see electrical installation, page 7
Typical Response Time	<200 ms
Integration / Modbus Register	We refer to the detailed Modbus register of the FSC-UFC24-230. Available under www.smttec-ag.ch/en/products

Communication / BACnet



Protocol	BACnet MS/TP
Medium	RS-485, not electrically isolated
Number of Devices per Line	65 (without repeater)
Baud Rates	9'600, 19'200, 38'400, 76'800 bps (auto detect)
Address	1..127 (0 reserved for broadcast)
Termination	120Ω line termination. Jumper available on extra pin on PCB. Position of jumper if FSC-UFC24-230 is last BACnet device in line, see electrical installation, page 7
Typical Response Time	<100 ms
BACnet Device Instant	Automatically assigned by physical address, writable
Integration / BACnet Objects, Pics	We refer to the detailed BACnet objects, pics of the FSC-UFC24-230. Available under www.smttec-ag.ch/en/products

Safety

Protection Class	II
Protection Degree	IP42, housing of non-flammable polycarbonate
Electromagnetic Tolerance	CE in accordance with 2004/108/EC
Low Voltage Directive	CE in accordance with 2006/95/EC
Mode of Operation	Type 1 (EN 60730-1)
Rated Impulse Voltage	2.5 kV (EN 60730-1)
Degree of Pollution of Environment	2 (EN 60730-1)
Ambient Temperature	-20 °C to + 50 °C
Storage Temperature	-20 °C to + 80 °C
Humidity Test	95% RH, non-condensing (EN 60730-1)
Maintenance	Maintenance free

Mechanical Data	Width	120 mm
(Dimensions / Weight)	Length	153 mm
	Height	57 mm (with bracket)
	Weight	ca. 442 g (with bracket)
	See drawings page 5	
Installation	The FSC-UFC24-230 is directly installed at or close to the fire or smoke extraction damper. The bracket can be pre-installed. The FSC-UFC24-230 can be snapped onto the bracket any time (at the damper manufacturer or at the job site).	
Electrical Installation	See details page 7.	
Safety Notes	<p>The FSC-UFC24-230 is not allowed to be used outside the specified field of application, especially in aircraft or in any other airborne means of transport.</p> <p>The company buying and / or mounting the FSC-UFC24-230 on site bears full responsibility for the proper functioning of the whole system. Only authorized specialists may carry out the installation. All applicable legal or institutional installation regulations must be complied with during installation.</p> <p>The device contains electrical and electronic components and is not allowed to be disposed of as domestic refuse. All locally valid regulations and requirements must be observed.</p>	
Product Features / Application	<p>The FSC-UFC24-230 is used together with a fire or smoke extraction damper actuator to control and monitor one fire or smoke extraction damper. With separate phase for the electronics of the device (24 V AC/ DC) and any actuator power supply with the corresponding current between 24 V AC/DC and 230 V AC. When the power supply (phase) to the actuator is interrupted, the fire damper actuator closes. The FSC-UFC24-230 is still powered and reports the damper position to the controller. It offers Modbus, BACnet or analog connection and is normally mounted at or close to the damper. Following control modes can be chosen through dip switch terminal:</p> <ul style="list-style-type: none"> • Fire or smoke extraction application • Bus protocols: Modbus or BACnet <p>Conventional: Analog output and digital input signals for conventional application.</p> <p><i>This digital input in the FSC-UFC24-230 always overrides the bus commands.</i></p> <p>Universal System Link between fire or smoke extraction damper and any Modbus or BACnet system or analog control.</p>	
Power Supply	The FSC-UFC24-230 needs to be powered up with 24 V AC/DC for the controls device and between 24 V AC/DC and 230 V AC for the connection of the actuator. The FSC-UFC24-230 provides the power supply to the actuator and to other connected devices (e.g. smoke detector). For more details see page 7.	

Control *Conventional*

The FSC-UFC24-230 offers the option to work without the bus communication (Modbus / BACnet) and can be controlled in a conventional way. There is one input to open or close the damper. The home position is depending on the fire or smoke extraction application. It is also possible to monitor the damper position conventional through a digital output signal.

There is one analog output to signalize the status of the FSC-UFC24-230 and the actuator. This analog output can be read from any controller.

Communication *Serial Communication – RS-485*

Through Modbus RTU (RS-485) or BACnet MS/TP (RS-485).

We refer to the detailed information in the Modbus register / BACnet object list / pics of the FSC-UFC24-230. Available under www.smtec-ag.ch/en/products.

Actuator Connection 3-pole AMP plug and terminal connection for standard 24 V AC/DC ... 230 V AC fire or smoke extraction actuator. 6-pole AMP plug and terminal connection for 2 internal actuator end switches. Identification of the end position switches of the actuators.

Additional Connections *Inputs*

2-pole AMP plug and 3-pole connection (terminal) for thermoelectric tripping device (potential free contact), 4-pole connection (terminal) for smoke detector incl. power supply (potential free contact). 2-pole connection (terminal) for digital input (potential free contact) for conventional application.

Output

2-pole connection (terminal) for analog output. Indicates the status of the FSC-UFC24-230.

Cable Specification



120Ω at 1 Mhz. Made of 24# flexible twisted pairs overall foil + braidshielded and overall jacketed with a flexible compound for indoor use, or similar. Cable type: Belden 3105a or equivalent.

IMPORTANT: SMT takes no responsibility of the functionality of the units/network if a different cable is used to the one specified here.

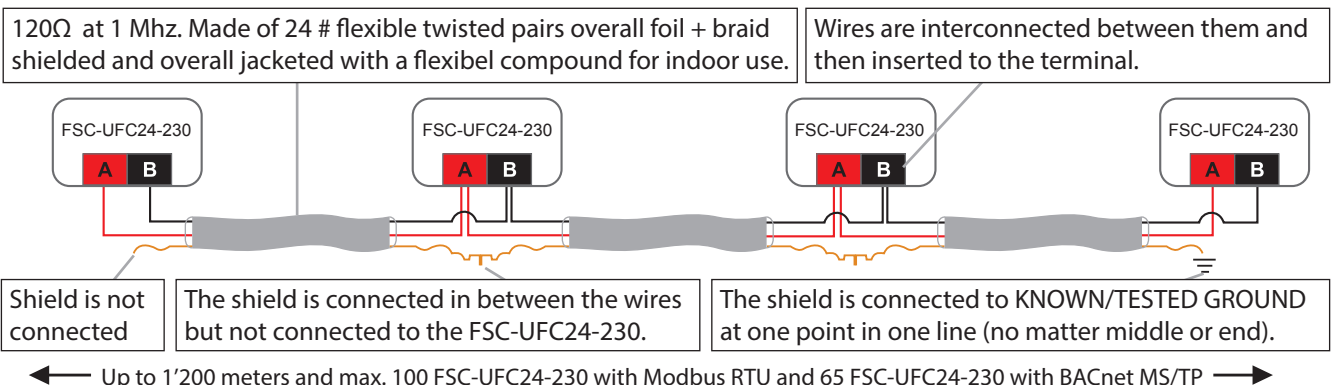

Dimensions

FSC-UFC24-230



Mounting Bracket

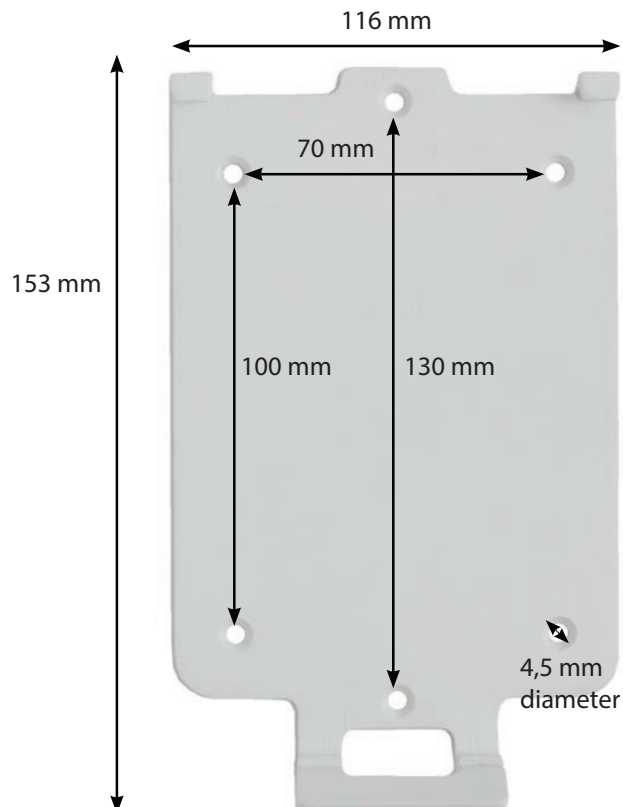

Removing the Cover of the Housing

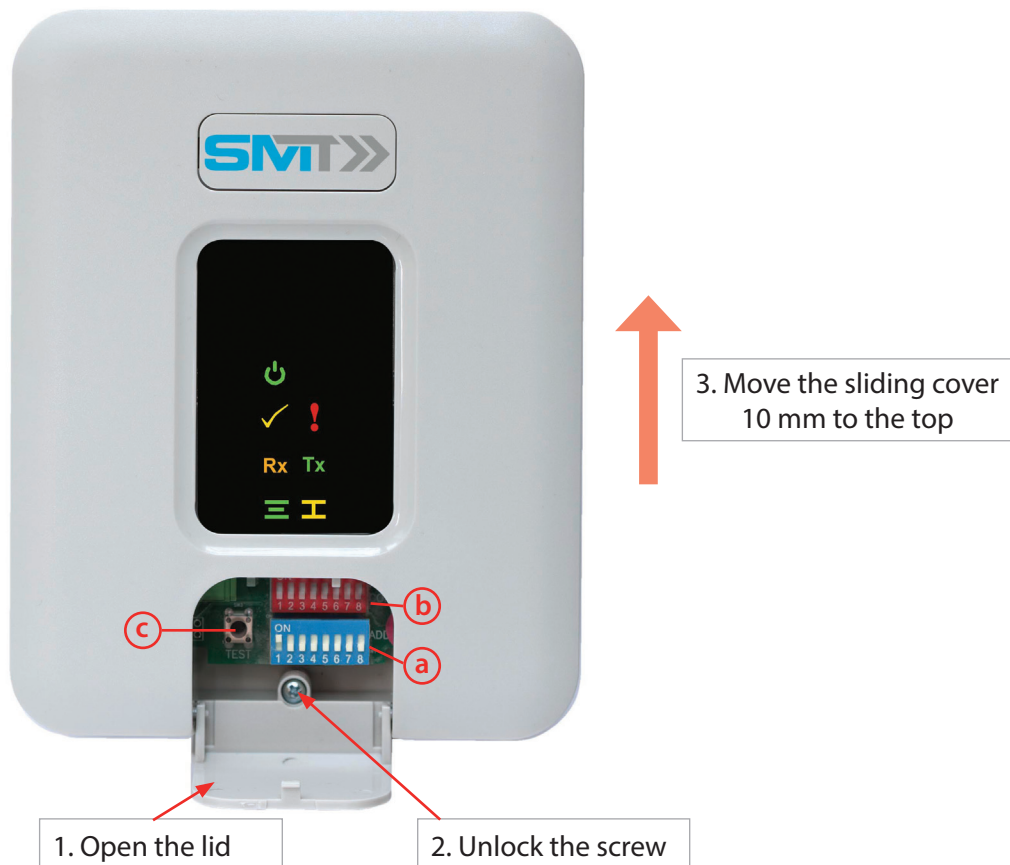

1. Open the small lid on the lower end of the housing by flapping up the cover
2. Unlock the screw which is placed on the lower end in the middle
3. Move the sliding cover 10 mm to the top
4. Remove the cover

Lid for Easy Access to Dip Switch Terminals (Configuration / Addressing) and Test Button

- (a)** The blue coloured dip switch terminal is for the Modbus or BACnet addressing.
- (b)** The red one for the configuration.
- (c)** Test button: For detailed explanation of the function of the test button see page 16.

Electrical Installation

General Information

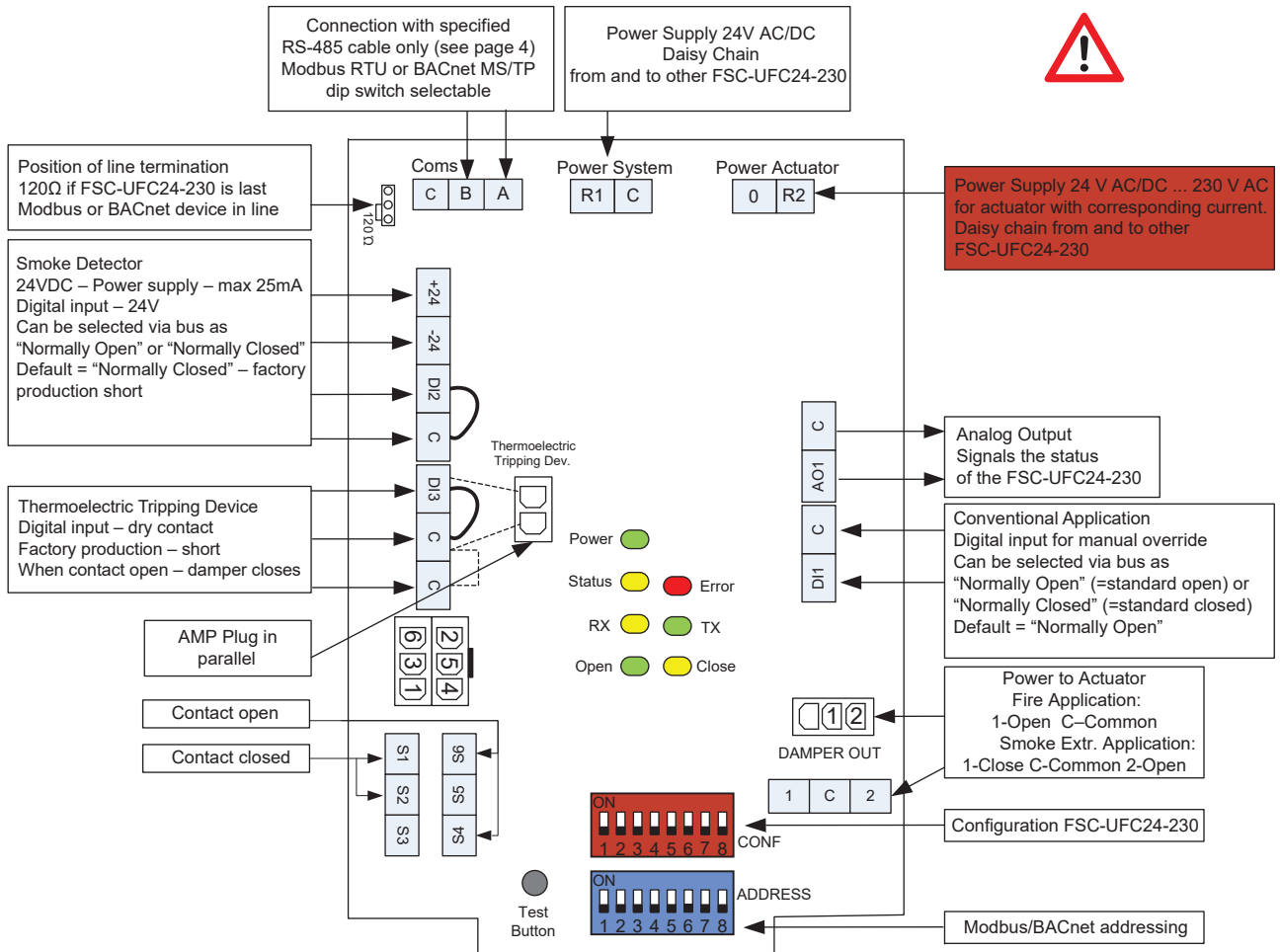

Power Supply

Main Power - FSC-UFC24-230

The FSC-UFC24-230 offers dual power supply of

- 24 V AC / DC for the system, smoke detector, thermoel. tripping device, end switches of the actuators
- 24 V AC/DC ... 230V AC for the power supply of the fire or smoke extraction damper actuator. The current connected to 0;R2 must correspond with the current of the actuator (e.g. power supply 230 V AC if the current of the actuator is 230 V AC)

When supplying power to several FSC-UFC24-230 from one power source, make sure that the polarity of the connections is correct (phase to phase, Com to Com)!

Serial power supply (daisy chain) of more than one FSC-UFC24-230 (24 V AC / DC and i. e. 230 V AC) is possible.

IMPORTANT:



- **The correct wiring is very important in regards to the 230 V power supply!**
- **The polarity, phase to phase and com to com, must be respected when connecting to the power supply network and also when connecting multiple FSC-UFC24-230!**
- The wiring of the actuator must be done in the correct way and according to the manufacturer's instructions. Especially when using actuators without plugs it is important to have a close focus on the polarity of the cable connection that means, to consider the correct allocation of phase and com!
- **All connections have to be fixed before putting power to the devices. Beside the risk of electrical shock, it is also possible to destroy the FSC-UFC24-230 when not proper handled.**

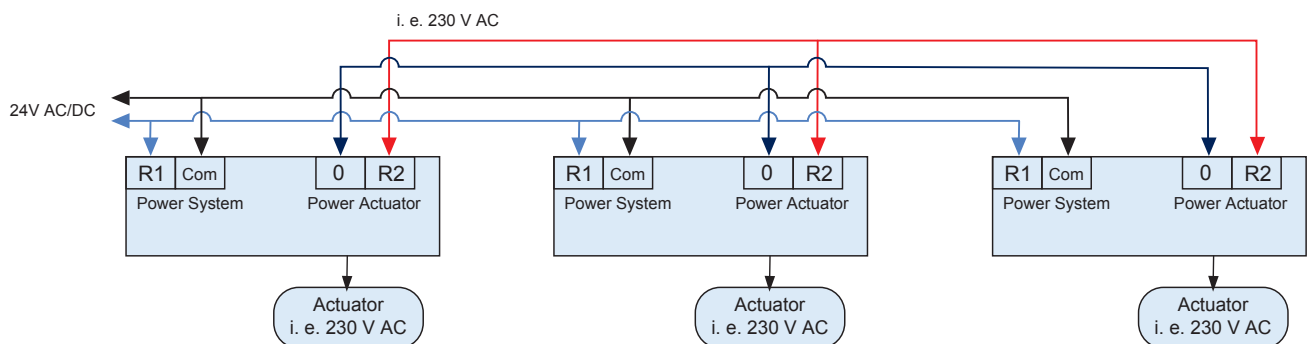

Modbus and BACnet Addressing

If the FSC-UFC24-230 is used in combination with the Controllers of SMT (FSC-M30, FSC-M240, FSC-M240-MX), the addressing is recommended to be done in consecutive order. Dip switch 8 not in use.

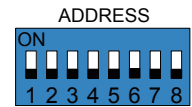

Address	Switches On	Address	Switches On	Address	Switches On	Address	Switches On
0	Broadcast-not in use	33	1+6	66	2+7	99	1+2+6+7
1	1	34	2+6	67	1+2+7	100	3+6+7
2	2	35	1+2+6	68	3+7	101	1+3+6+7
3	1+2	36	3+6	69	1+3+7	102	2+3+6+7
4	3	37	1+3+6	70	2+3+7	103	1+2+3+6+7
5	1+3	38	2+3+6	71	1+2+3+7	104	4+6+7
6	2+3	39	1+2+3+6	72	4+7	105	1+4+6+7
7	1+2+3	40	4+6	73	1+4+7	106	2+4+6+7
8	4	41	1+4+6	74	2+4+7	107	1+2+4+6+7
9	1+4	42	2+4+6	75	1+2+4+7	108	3+4+6+7
10	2+4	43	1+2+4+6	76	3+4+7	109	1+3+4+6+7
11	1+2+4	44	3+4+6	77	1+3+4+7	110	2+3+4+6+7
12	3+4	45	1+3+4+6	78	2+3+4+7	111	1+2+3+4+6+7
13	1+3+4	46	2+3+4+6	79	1+2+3+4+7	112	5+6+7
14	2+3+4	47	1+2+3+4+6	80	5+7	113	1+5+6+7
15	1+2+3+4	48	5+6	81	1+5+7	114	2+5+6+7
16	5	49	1+5+6	82	2+5+7	115	1+2+5+6+7
17	1+5	50	2+5+6	83	1+2+5+7	116	3+5+6+7
18	2+5	51	1+2+5+6	84	3+5+7	117	1+3+5+6+7
19	1+2+5	52	3+5+6	85	1+3+5+7	118	2+3+5+6+7
20	3+5	53	1+3+5+6	86	2+3+5+7	119	1+2+3+5+6+7
21	1+3+5	54	2+3+5+6	87	1+2+3+5+7	120	4+5+6+7
22	2+3+5	55	1+2+3+5+6	88	4+5+7	121	1+4+5+6+7
23	1+2+3+5	56	4+5+6	89	1+4+5+7	122	2+4+5+6+7
24	4+5	57	1+4+5+6	90	2+4+5+7	123	1+2+4+5+6+7
25	1+4+5	58	2+4+5+6	91	1+2+4+5+7	124	3+4+5+6+7
26	2+4+5	59	1+2+4+5+6	92	3+4+5+7	125	1+3+4+5+6+7
27	1+2+4+5	60	3+4+5+6	93	1+3+4+5+7	126	2+3+4+5+6+7
28	3+4+5	61	1+3+4+5+6	94	2+3+4+5+7	127	Reserved factory defaults
29	1+3+4+5	62	2+3+4+5+6	95	1+2+3+4+5+7		
30	2+3+4+5	63	1+2+3+4+5+6	96	6+7		
31	1+2+3+4+5	64	7	97	1+6+7		
32	6	65	1+7	98	2+6+7		

Configuration through Dip Switch

Default Dip Switch Position

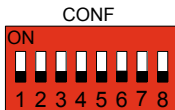

Configuration Possibilities

Pin	Off (Default)	On
1	Bus	Analog
2	Fire Application	Smoke Extr. Application
3	Modbus RTU	BACnet MS/TP
4	Baud Rate (Off-Default)	
5	Baud Rate (Off-Default)	
6	Not In Use=Off	
7	Smoke Detector Alarm "System"	Smoke Detector Alarm "Actuator"
8	Not In Use=Off	

Information Pin 2:

If Pin 2 is changed from fire to smoke extraction application or from smoke extraction to fire application, the FSC-UFC24-230 needs to be taken off the power supply and put back again to activate the new mode.

Information Pin 3:

When a FSC-UFC24-230 has been connected and operated in one bus protocol first (Modbus or BACnet) and then will be operated by the other (BACnet or Modbus) the factory reset functionality in the FSC-UFC24-230 MUST be activated by bus communication as soon as it is connected to the other protocol (Modbus register 33, BACnet Object List BV 19). **If the FSC-UFC24-230 is used in connection with the Controllers of SMT (FSC-M30, FSC-M240, FSC-M240-MX), Pin 3 has to be on ON (BACnet).**

Explanation Pin 7:

- Smoke Detector Alarm "System" = The signal of the smoke detector is transferred directly to the system and processed there.
- Smoke Detector Alarm "Actuator" = The signal of the smoke detector is directly linked with the actuator. In case of a smoke detector alarm the fire damper connected to the same FSC-UFC24-230 will be closed. The signal of the smoke detector is forwarded to the controller.

The above is only valid for the fire safety application. In the smoke extraction application the signal of the smoke detector has no direct influence to the actuator. The signal will be forwarded to the system in any case.

Baud Rate Selection Modbus

This has to be done when choosing Modbus only.
Single Writing!

	9600 (Default)	19200	38400	76800
4	Off	On	Off	On
5	Off	Off	On	On

Baud Rate Selection BACnet

Baud rate in BACnet is automatically detected.
Single Writing!

Connection Details

Fire Damper Actuator (spring return) – Connections

When the actuator has power it is open, when there is no power the actuator is closed with the spring.

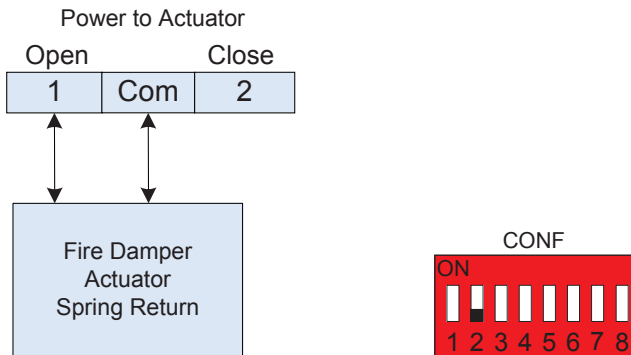

Smoke Extraction Damper Actuator – Connections

If the actuator is powered up the smoke extraction damper is either open or closed. If the FSC-UFC24-230 sends the smoke extraction damper actuator the open signal, pin OPEN is powered. If the FSC-UFC24-230 sends the smoke extraction damper actuator the close signal, pin CLOSE is powered.

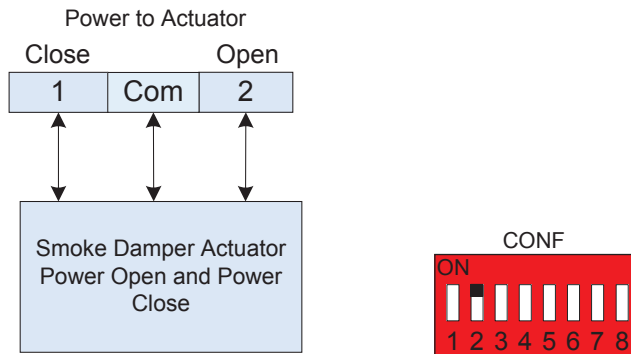

Fire Damper

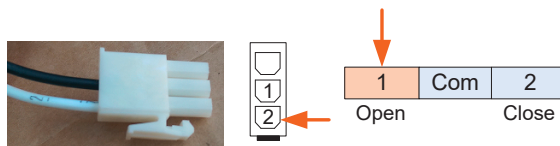

When the FSC-UFC24-230 is powered up, the power to the actuator is on output 'open' (pin nr 1).

Smoke Extraction Damper

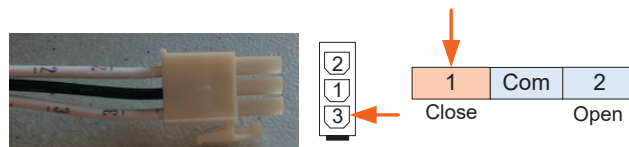

On power up the CLOSE output will be ON. During normal operation the FSC-UFC24-230 in this application ONLY, will hold the last command on memory (only valid for smoke extraction application)

After Connection - Power Reset:

- **Fire Damper Application** will always go to OPEN.
- **Smoke Extraction Damper Application** will hold last command on memory.

Thermoelectric Tripping Device - Connection

Digital input volt free, normally close as default (can be changed on bus). Factory shorted.
 When this input is active the damper will close and you can override from the bus.
 The 2 connections, the normal quick terminals and the AMP connector are in parallel.
 AMP plug 2-pole. Quick connector 3-pole.

When a thermoelectric tripping device is mounted in the 2-pole AMP plug, the factory production mounted jumper between DI3 and C must be removed!

**The thermoelectric tripping device is used exclusively for the fire safety application.
 For the smoke extraction application this element has no function.**

Electrical Installation Thermoelectric Tripping Device

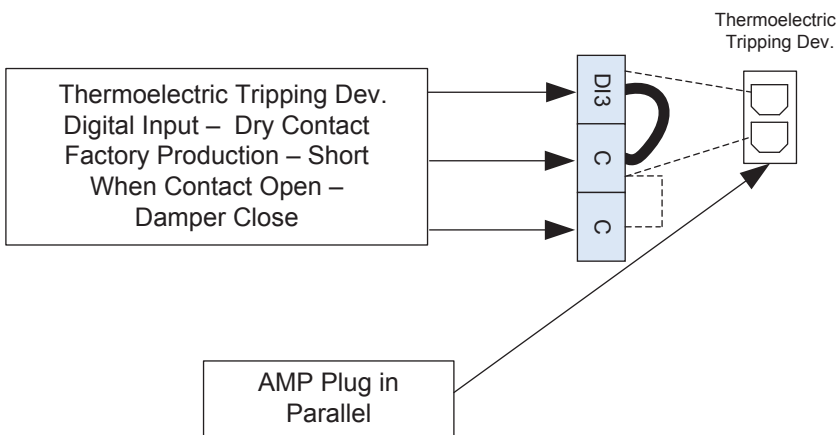

Smoke Detectors – Connections

Smoke detector connection

Possibility to connect one smoke detector

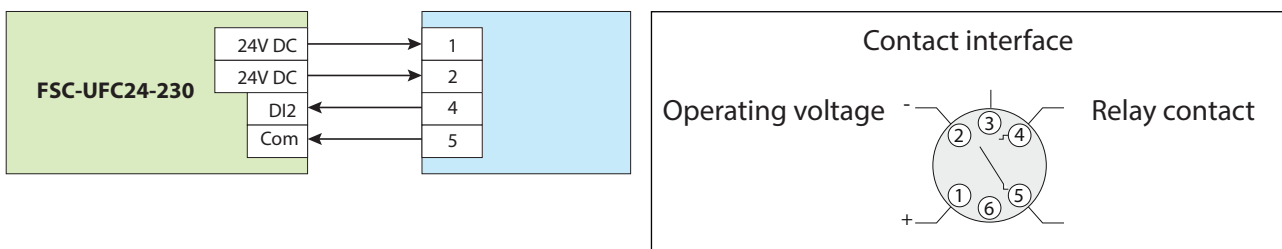

Conventional Application

The FSC-UFC24-230 has the option to work without the bus communication connected. There is one digital input to open or close the damper. The initial position is depending on the fire or smoke extraction application. It is also possible to monitor the damper position conventionally through a digital output signal.

The analog output, signals the status of the FSC-UFC24-230:

10 V - all functions OK

0 V - one or more alarms active.

No power supply to the FSC-UFC24-230

This output can be connected in parallel between the various FSC-UFC24-230 in order to monitor their status. Current output max is 5mA.

Digital input volt free, normally open as default (can be changed on bus).

The digital input allows to control the damper position through an external contact/device.

Selection of the analog settings by dip switch.

This digital input for the conventional application in the FSC-UFC24-230 overrides always the bus commands.

Digital output: The feedback signals (on / off) of the actuator can be forwarded via the connections S1 and S2 (actuator/damper closed) and / or S4 and S6 (actuator/damper open) to any control and monitoring device.

Electrical Installation for Conventional Application

Feedback signals from the FSC-UFC24-230:

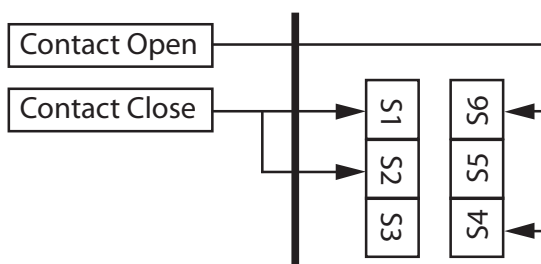

Electrical Installation for Conventional Application

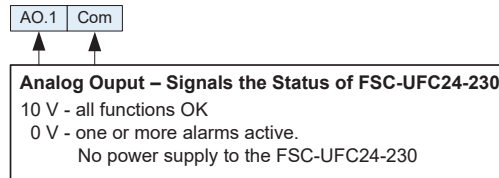



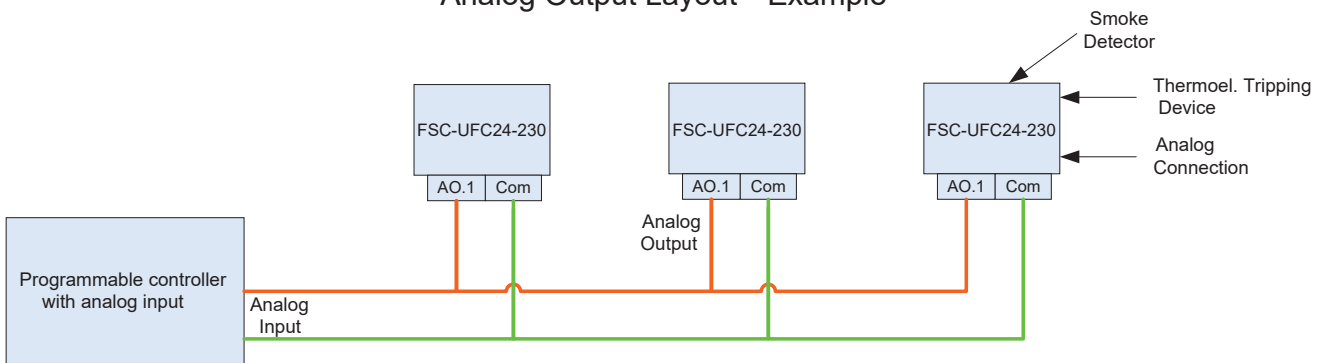



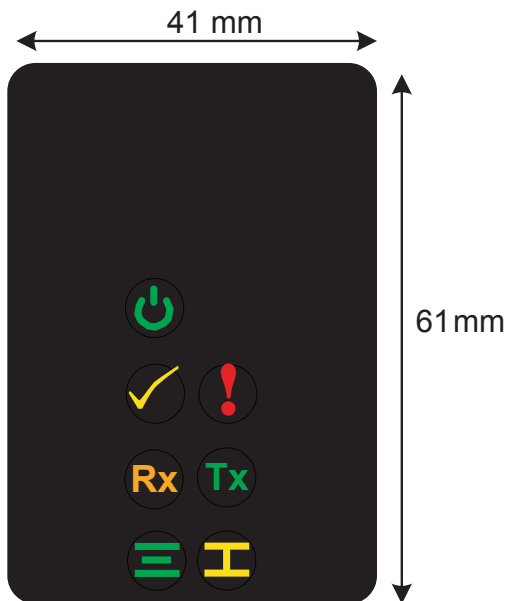

Analog Output Layout - Example



Explanation of LEDs

The LEDs are only visible if they are active. If not active the symbols will not appear.



Led	Color	Action	Description
Power	 Green	On	Power is connected
Status		Off	Bus operation
		On	Analog connection
Error		Flash Interval 1 sec	Actuator did not reach end switch position within the set time
		Flash Interval 2 sec	Smoke detector alarm
		Flash Interval 3 sec	Thermoelectric tripping device alarm
		Flash Interval 0.3 sec	Error on 2 functions or more Error message test report
		Flash Interval 5 sec	General alarm
Rx	 Yellow	Flash	Receive data
Tx	 Green	Flash	Transmit data
Close	 Yellow	On	Damper close
Open	 Green	On	Damper open
Close + Open Flashing	Damper is moving		

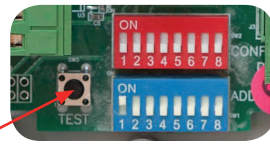

Functionality of Test Buttons

Depending on the application (fire or smoke extraction) the test button creates different test scenarios.

Fire Application:

- Power on the FSC-UFC24-230: The actuator opens the fire damper until the end position is reached
- The permanent pushing of the test button will interrupt the power supply to the actuator. Spring is closing the actuator
- As soon as the test button is released the power comes back to the actuator and the damper will open again

Smoke Extraction Application:

- Power on: actuator makes self-test and remains in position defined by controls
- Pushing test button changes command of the actuator – actuator (damper) runs into opposite direction
- Release test button: actuator (damper) runs back into last defined position

If an FSC-UFC24-230 is newly connected to a bus network:

Press the test button for 5 seconds.

The FSC-UFC24-230 is then recognized and integrated as participant in the bus network. This process can be repeated as often as needed.

Run Time Monitoring of Actuator

The FSC-UFC24-230 is equipped with an actuator run time monitoring function. This function monitors the time required by the actuator from leaving of the one and reaching of the other end switch. If the actuator does not reach the other end switch in the specified time an error message is sent.

The default value for the actuator run time is 90 seconds. This can be adapted via Modbus or BACnet from 0...360 seconds.

Full Auto Test Application

The FSC-UFC24-230 offers a 'Full Auto Test' function. This can be controlled through the Modbus or BACnet controller.

Function

Base for this function is the run time monitoring of the actuator.

Fire Damper

To start the full auto test functionality, the corresponding bus-register has to be activated via bus. By starting the full auto test, the timer of the run time monitoring starts to count the time and the fire damper actuator is closing (spring) and remains in the closed position until the timer of the set running time has reached the set time. Then the actuator will open again automatically until the end switch has been reached. The timer of the run time monitoring starts to count again as soon as the command 'open' has been sent. Once the timer of the set running time has reached the set time, the FSC-UFC24-230 will go back into normal operation mode and a feedback "full auto test ok" is activated. If one of the end switches is not reached within the defined running time, an error message is activated.

Smoke Extraction Damper

To start the full auto test functionality, the corresponding bus-register has to be activated via bus. By starting the full auto test, the timer of the run time monitoring starts to count the time and the smoke extraction damper actuator is moving to the opposite direction and remains in that position until the timer of the set running time has reached the set time. Then the actuator will automatically move back to the original position until the end switch has been reached. The timer of the run time monitoring starts to count again as soon as the command 'opposite direction' has been sent. Once the timer of the set running time has reached the set time, the FSC-UFC24-230 will go back into normal operation mode and a feedback "full auto test ok" is activated. If one of the end switches is not reached within the defined running time, an error message is activated.

Bus Monitoring Application

The FSC-UFC24-230 is equipped with a Bus Monitoring Function. If the bus signal to the FSC-UFC24-230 is interrupted the damper will move to the safety position after the defined period of time and remain there until the bus functionality is back to normal operation.

Objects

There are 2 objects which can be activated by Modbus or BACnet:

- Logic Alarm / Bus Monitoring Function
- Logic Alarm Delay / Set Delay (time in sec)

Default settings:

Logic Alarm / Bus Monitoring Function not active

Activation (via Bus):

- Logic Alarm / Bus Monitoring Function 1 (on)
- Logic Alarm Delay is activated, default delay time is 120 sec. Option to set the delay time via bus between 30...360 sec

Functionality

Fire Damper

After the set delay time ("Delay Alarm" communication) the fire damper will move to the closed position and remains closed until the bus functionality is back to normal operation.

Smoke Extraction Damper

If the smoke extraction damper is closed:

After the set delay time ("Delay Alarm" communication) the smoke extraction damper will move to the open position and remains open until the bus functionality is back to normal operation.

If the smoke extraction damper is open:

The smoke extraction damper remains in the open position even if the bus signal is interrupted.



Systems & Modules Technology AG
Bachtelstrasse 32
CH-8636 Wald
Switzerland
Phone: +41 55 241 10 20
Mail: info@smtec-ag.ch