

square perforated ceiling air vents



DESCRIPTION

KPNS/CP2 are rectangular, perforated air vents, to be installed in low- and mid-pressure systems. The air vent is designed to work with constant or variable air flow. The air can be supplied with temperature lower by 12 °C than the temperature in the room, which makes the air vent perfect for cooling rooms which have strict microclimate requirements.

KPNS can work both in air-supply and air-exhaust systems. It is recommended to install it in the ceiling level.

Thanks to their small dimensions and unpretentious looks, the KPNS/CP2 air vents may be easily implemented in modern ceiling systems.

SHORT CHARACTERISTIC

- short stream range
- possibility to install with an SR/ KPNS/CP1 plenum box
- painted with RAL9010 as standard
- can be painted any colour of the RAL palette upon special request

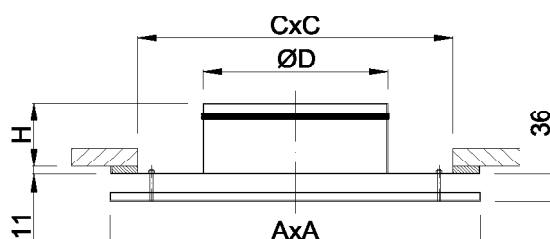
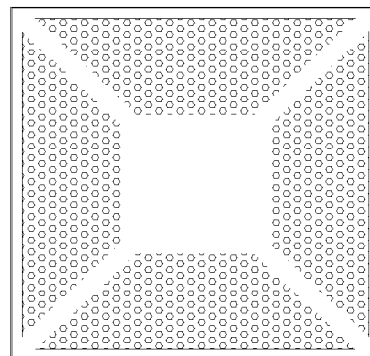

STANDARD VALUES

	125	160	200	250	315	400
ØD [mm]	123	158	198	248	313	398
A [mm]	235	295	395	495	595	595
C [mm]	200	260	360	460	560	560
H [mm]	138	148	158	158	158	158

C - size of the mounting hole

ORDER CODE

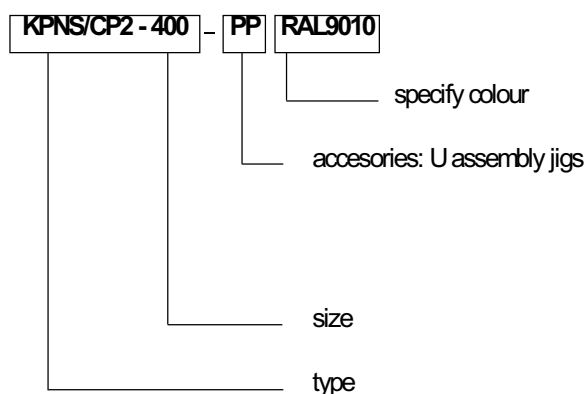

square perforated ceiling air vents

ACCESSORIES

U Assembly jigs

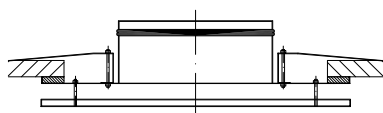

MOUNTING

The KPNS/CP2 air vents may be mounted directly in a round ventilation shaft or in the SR/KPNS plenum box. In both cases, screws or rivets should be used for installation.

In the case of mounting the air vent directly to a false ceiling, it is necessary to make a CxC mounting hole in the ceiling and use factory supplied U-type mounting pegs.

Seal the connection between the ceiling and the air vent.

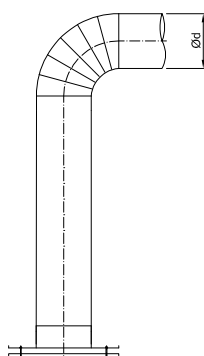

CHARACTERISTICS

The diagrams present air efficiency V [m³/h], pressure loss p (Pa), stream range L [m] for the final speed of 0.25 m/s and level of loudness [dB(A)].

Given values of stream range L and pressure loss p refer to 4-way air-exhaust from the air vent. In other cases, these values should be updated with data given in the table below.

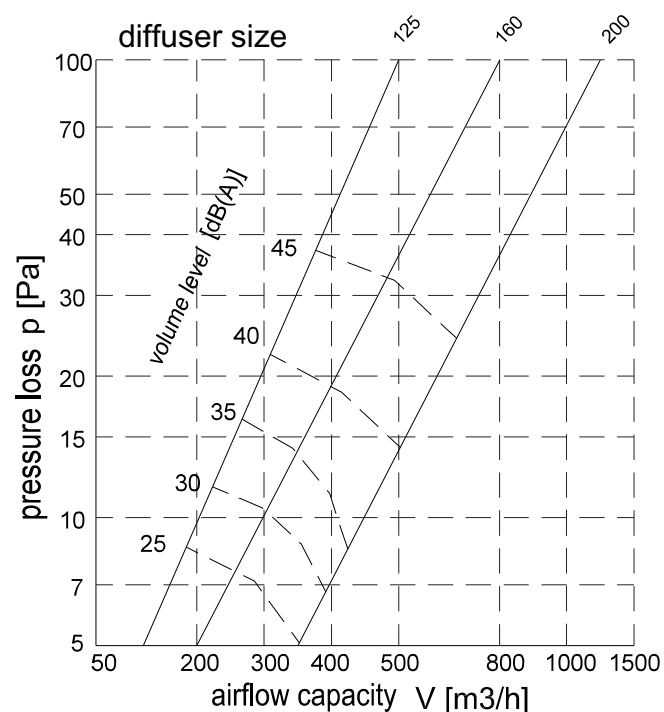

KPNS/CP2 air vents

