

DESCRIPTION

NSRN 1 and NRSN 2 air vents are used for hot and cold air-supply/air-exhaust in offices and shopping centres. Air vents can be installed on the ceiling, where certain aesthetic standards are required. They have an adjustable air system (vertical and horizontal), which is perfect for constant supply of air.

FEATURES

- The vent is made of powder coated sheet metal in RAL 9010.
- The vent can be painted any colour of the RAL palette upon special request

Size	N mm	A mm	B mm	E mm	F mm
100	100	190	215	51	58
125	125	215	240	51	58
160	160	305	330	71	93
200	200	345	370	71	93
250	250	395	420	71	93
315	315	460	485	71	93

ORDER REFERENCE

NSRN - 1 - 100 - RAL9010

colour

size

version:
1 ; 2

type:
NSRN

NSRN 2

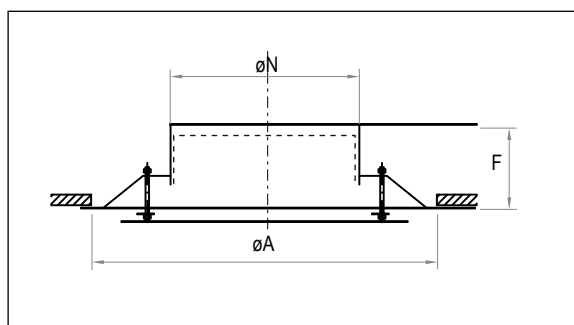

Size	N mm	A mm	F mm
100	100	295	75
125	125	295	75
160	160	295	95
200	200	595	110
250	250	595	110
315	315	595	110

2.17 NSRN Air vent

ceiling air vent with adjustable air-supply

2

Vertical air-supply

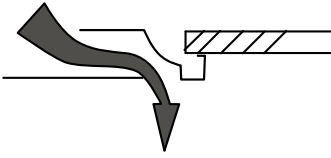

Horizontal air-supply

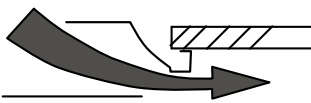

FAST SELECTION DIAGRAM

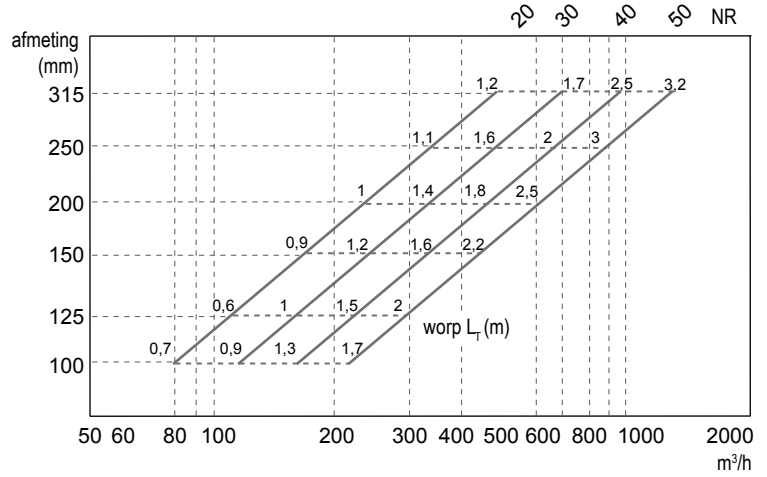

EXAMPLE

DECREASE OF PRESSURE WITH A CHOKE VALVE

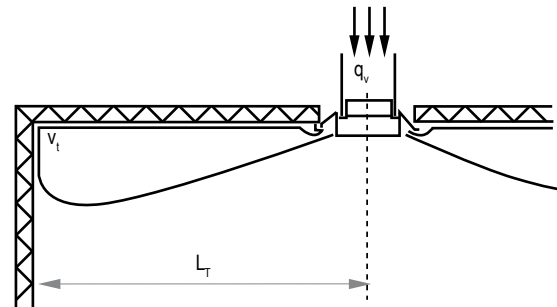
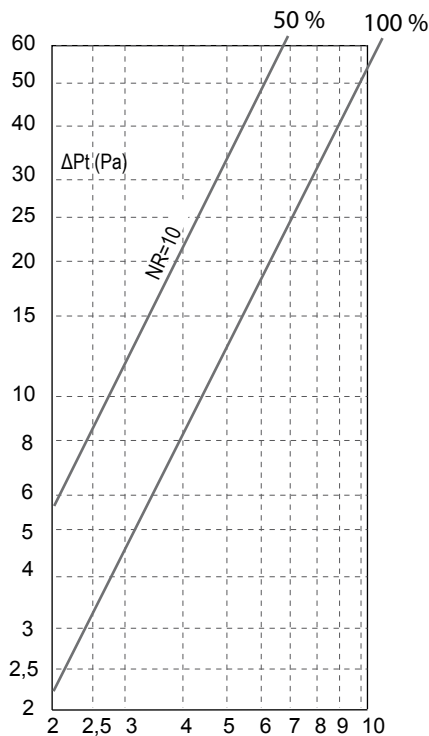

Sample data:

- $q_v = 0,07 \text{ m}^3/\text{s}$
- $L_T = 1 \text{ m}$ at $v_t = 0,50 \text{ m/s}$

Solution:

- size 200
- velocity $v_k = 4,1 \text{ m/s}$
- noise NR 22
- total pressure at wide open throttle: $\Delta P_t = 8,5 \text{ Pa}$.

A _k - i A _n - (m ²)						
Size	100	125	160	200	250	315
A _k	0,0044	0,0066	0,0110	0,0171	0,0270	0,0429
A _n	0,0079	0,0123	0,0201	0,0314	0,0491	0,0779