



PLI

Ceiling diffuser



Overview

Description

The PLI is a square ceiling-mounted supply air diffuser designed for flush installation in modular false ceiling systems. It is intended for use in offices, schools, healthcare facilities, and other similar indoor environments where both discreet appearance and reliable performance are required. The diffuser features a circular front slot in combination with an aerodynamically shaped back connection section, enabling smooth 360-degree horizontal airflow. This design promotes even air distribution and efficient mixing with the room air. The airflow adheres to the ceiling surface (through the Coandă effect), reducing the risk of draughts in the occupied zone, even at lower airflows or when supplying cooler air. The PLI maintains a uniform visible design regardless of spigot size and is suitable for both supply and extract air, without requiring modification. This ensures a consistent appearance across different areas of a building. The diffuser is connected to a TK commissioning box, which includes sound-absorbing insulation, an air deflector plate, and an integrated damper module with measuring tubes and cords for proper airflow adjustment. The PLI can handle temperature differences of up to 12 °C below room temperature, making it suitable for cooling applications while maintaining thermal comfort and air quality.

Optional accessories

- **TK:** A commissioning box, featuring low build height, environmentally friendly sound-absorbent insulation, a supply air distribution plate, and a removable damper module for commissioning and measuring airflow. The sound insulation offers optimal noise attenuation, ensuring quiet operation to enhance comfort in various settings. The damper module is equipped with a measurement flange and hoses for precise airflow measurement, and the damper blade is fitted with adjustment cords for easier commissioning and securing the airflow. The low height is possible by the internal socket design of the diffuser connection, minimising the total height of the diffuser and box, when assembled together.
- **MN:** Sleeve/nipple for installation with a pressure box in suspended ceilings. The accessory adds 40 mm to the installation height.



Main characteristics

- Square ceiling diffuser for supply or extract air
- Designed for flush mounting in suspended ceiling systems
- Circular slot opening for a 360 degree air distribution
- Optimal Coandă effect at higher temperature differences and lower airflows
- High induction with quick mixing of supply air
- Low noise level
- Recommended to use with TK commissioning box

Applications

The PLI diffuser is ideal for ventilating spaces where discreet and efficient air distribution is required, such as offices, schools, hospitals, restaurant and retail stores. It is effective for both supply and extract air, making it versatile for various building types.

Materials and finish

The front diffuser plate is made of galvanized steel, the back section is made of sheet steel. The unit is powder coated in standard RAL 9003 white color. The air connection features an EPDM sealing.

Table 01 - Quick selection TK - 0-step

Size [mm]		Airflow [l/s] [m³/h] at different sound pressures*			
PLI	TK	25 [dB(A)]		30 [dB(A)]	
		Supply air	Exhaust air	Supply air	Exhaust air
160	160-160	58 [209]	73 [263]	67 [241]	89 [320]
200	200-200	75 [270]	94 [338]	86 [310]	113 [407]
250	250-250	126 [454]	132 [475]	149 [536]	157 [565]

*The given data are valid for a fully open damper.

Table 02 - Quick selection TK - 1-2 step

Size [mm]		Airflow [l/s] [m³/h] at different sound pressures*			
PLI	TK	25 [dB(A)]		30 [dB(A)]	
		[l/s]	[m³/h]	[l/s]	[m³/h]
160	160-100	41	148	48	173
	160-125	55	198	65	234
200	200-125	62	223	73	263
	200-160	80	288	92	331
250	250-160	91	328	105	378
	250-200	100	360	114	410

*The given data are valid for a fully open damper.

Installation

- The air diffuser is designed for installation in conventional lay-in type modular ceiling systems (standard T-grid T14/24).
- The front plate of the air diffuser is mounted using spacer legs that ensure it is always horizontal.
- The design allows for easy disassembly of the front plate and damper without tools for maintenance, such as cleaning the duct system.
- The spigot between the diffuser and the pressure distribution box can be extended with a circular duct. If the spigot exceeds 500 mm, extension of the measuring tube and damper cords is required.
- The spigot of the commissioning box is connected to the circular duct. The air diffuser is connected to the outlet spigot of the commissioning box. Connection to a straight-mounted flexible hose is possible but not recommended.
- The TK commissioning boxes can be installed directly after a bend. If installed after a T-joint, a straight section corresponding to 4x the diameter is required.
- For extra safety, the product is delivered with a safety cord attached to the front plate. During installation, the cord is secured with a simple loop on one of the spacers.

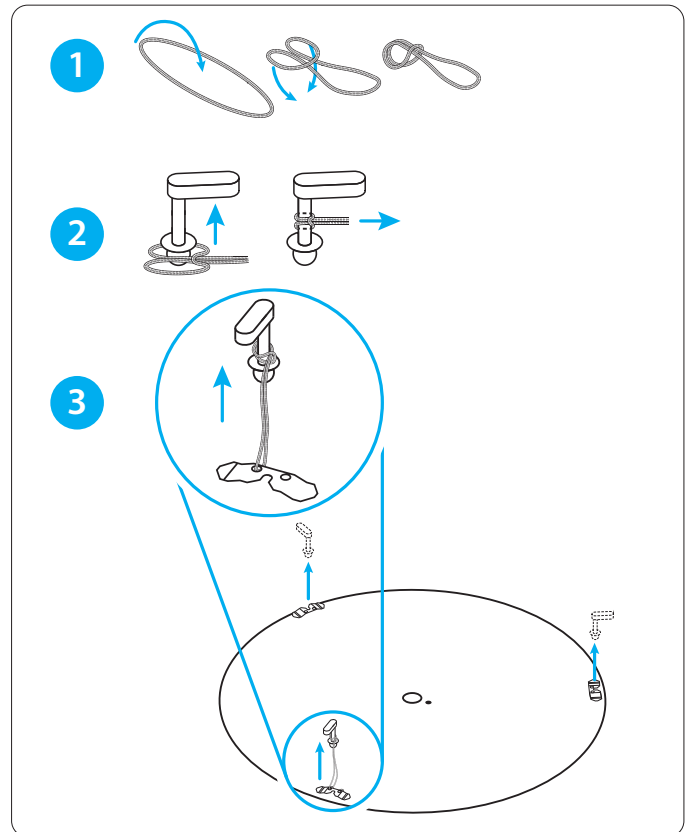

Figure 01 - The diffuser front plate is secured with the included safety cord attached through a simple loop on one of the spacer legs

Table 03 - Sound attenuation ΔL_D [dB] - TK commissioning box - 0-step

Size [mm]		Medium frequency [Hz]							
PLI	TK	63	125	250	500	1000	2000	4000	8000
160	160-160	19	15	14	18	18	14	18	19
200	200-200	18	14	14	19	15	14	18	21
250	250-250	18	12	15	19	15	14	18	19

Tol. ± 3 dB

Table 04 - Correction K_{OK} [dB] - TK commissioning box - 0-step

Size [mm]		Medium frequency [Hz]							
PLI	TK	63	125	250	500	1000	2000	4000	8000
160	160-160	+7	+8	+4	+2	0	-8	-21	-31
200	200-200	+7	+8	+4	+1	0	-7	-19	-29
250	250-250	+8	+11	+6	+1	-1	-7	-19	-29

Tol. ± 3 dB

Table 05 - Sound effect level L_{PA} - TK commissioning box - 0-step

Room volume	Room type	Correction
25 m ³	hard	+2 dB
25 m ³	normal	-2 dB
25 m ³	attenuated	-3 dB
150 m ³	hard	-5 dB
150 m ³	attenuated	-7 dB

Table 06 - Sound attenuation ΔL_D [dB] - TK commissioning box - 1-2-step

Size [mm]		Medium frequency [Hz]							
PLI	TK	63	125	250	500	1000	2000	4000	8000
160	160-100	21	20	15	14	17	18	18	16
	160-125	20	17	14	13	17	18	17	18
200	200-125	22	16	13	14	17	17	16	16
	200-160	21	14	13	15	19	18	15	17
250	250-160	22	13	13	15	19	16	15	16
	250-200	23	12	13	15	20	13	15	16

Tol. ± 3 dB**Table 07 - Correction K_{OK} [dB] - TK commissioning box - 1-2-step**

Size [mm]		Medium frequency [Hz]							
PLI	TK	63	125	250	500	1000	2000	4000	8000
160	160-100	+6	+7	+5	+2	-4	-4	-13	-22
	160-125	+5	+5	+5	+3	-2	-5	-16	-24
200	200-125	+7	+6	+4	+1	-2	-3	-13	-22
	200-160	+8	+6	+3	+3	-1	-6	-18	-27
250	250-160	+7	+6	+3	0	0	-4	-15	-23
	250-200	+11	+5	+1	+2	+1	-6	-19	-30

Tol. ± 3 dB**Table 08 - Sound effect level L_{PA} - TK commissioning box - 1-2-step**

Room volume	Room type	Correction
5 m ³	hard	+6 dB
5 m ³	normal	+4 dB
5 m ³	attenuated	+2 dB
25 m ³	hard	+2 dB
25 m ³	attenuated	-2 dB

Dimensioning

Sound data

For the reported sound data:

- Sound pressure level, L_{PA} dB(A), is read from the Dimensioning Diagram where ΔP_t (Pa) is total pressure drop and q (l/s or m³/h) is airflow.
- The designation of the commissioning box refers to the box's connection dimensions (mm), for example TK-160-100:
- Outlet Ø160 (towards diffuser) - Inlet Ø100 (towards duct).

The terms 0-step, 1-step and 2-step refer to the relationship between the commissioning box's connection dimensions:

- **0-step** – indicates there is no difference in duct dimension between the diffuser side and the duct side: TK-125-125, TK-160-160, TK-200-200, TK-250-250, TK-315-315
- **1-step** – indicates a difference of one duct dimension between the diffuser side and the duct side: TK-125-100, TK-160-125, TK-200-160, TK-250-200, TK-315-250, TK-400-315
- **2-step** – indicates a difference of two duct dimensions between the diffuser side and the duct side: TK-160-100, TK-200-125, TK-250-160, TK-315-200, TK-400-250
- Self-attenuation applies to diffusers with pressure box including outlet attenuation. (See: Table 03)
- Correction factor, K_{OK} [dB] for each octave band, is obtained from Table 04: Correction K_{OK} [dB].
- Sound pressure level, L_{PA} [dB], is calculated as $L_W = L_{PA} + K_{OK}$
- Measurements have been performed according to ISO 9614-2 and ISO 11691:1995.

Dimensioning diagram

For all dimensioning diagrams, the following applies:

- Correction of dB(A) value is performed depending on the pressure drop across the balancing damper, see Correction table - dB(A).
- For products with built-in dampers or products reported including a pressure box, 0% = closed damper, 100% = open damper.
- Sound pressure level, L_{PA} dB(A), in dimensioning diagrams corresponds to the A-weighted sound level in the reverberation field at 10 m² equivalent sound absorption area. This corresponds to 4 dB room attenuation in a normally damped room with 25 m³ room volume.
- ▼ = min. flow to obtain recommended measuring pressure.
- Throw length, $L_{0,2}$, indicates the distance from the air diffuser where the air velocity has decreased to 0.2 m/s, valid for isothermal supply at ceiling.

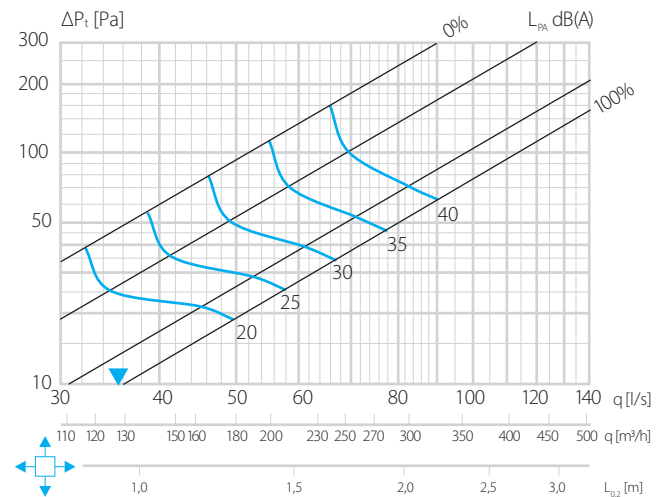

Diagram 01 - PLI-160 - TK-160-160 sound

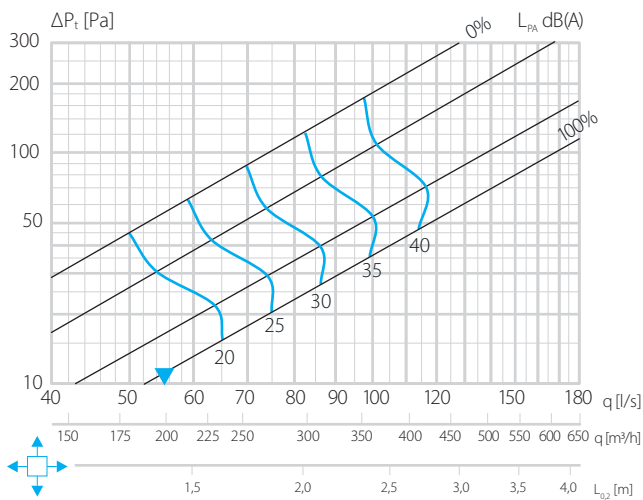

Diagram 02 - PLI-200 - TK-200-200 sound

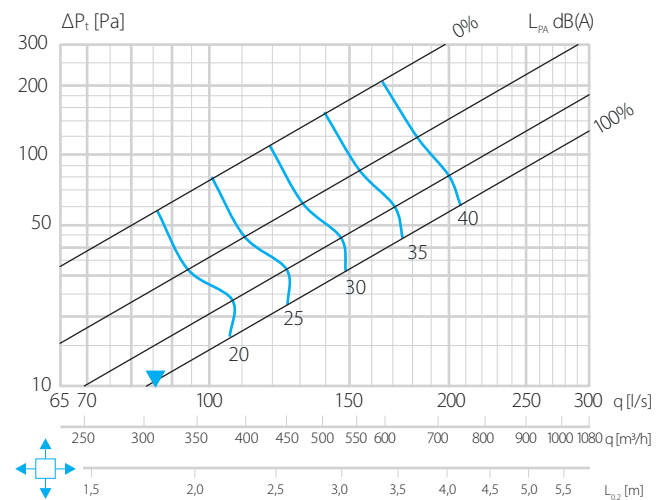

Diagram 03 - PLI-250 - TK-250-250 sound

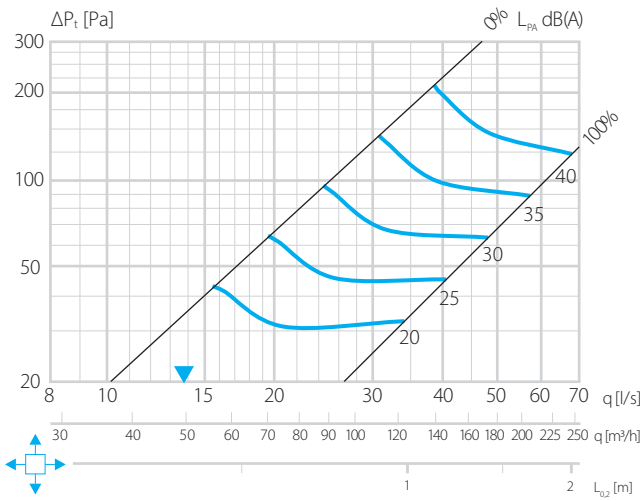

Diagram 04 - PLI-160 - TK-160-100 sound

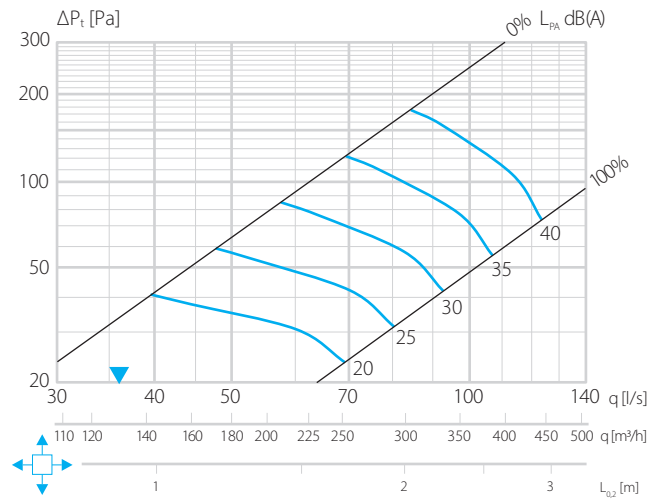

Diagram 07 - PLI-200 - TK-200-160 sound

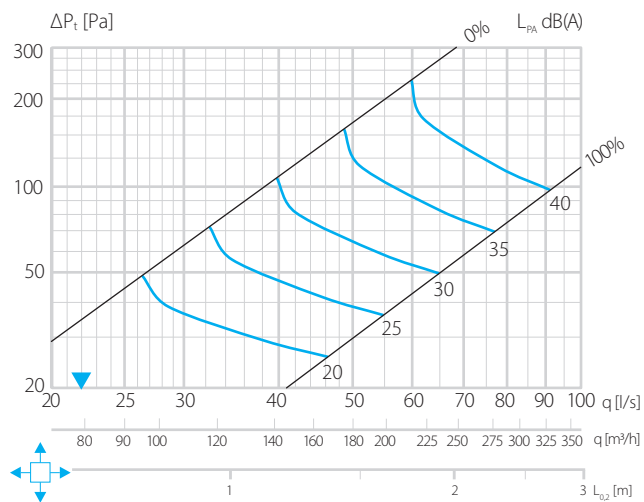

Diagram 05 - PLI-160 - TK-160-125 sound

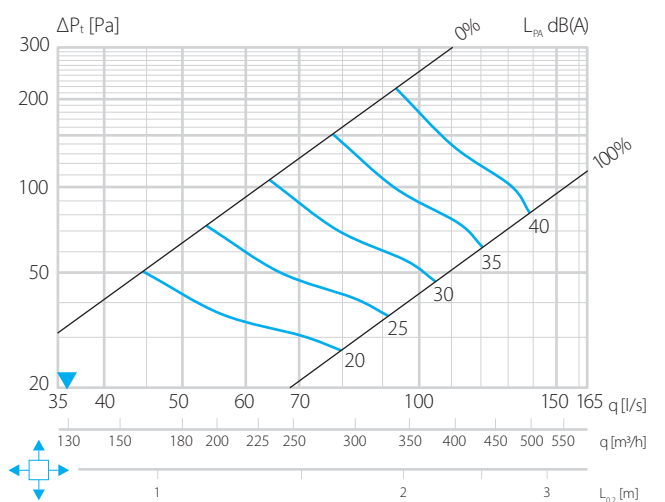

Diagram 08 - PLI-250 - TK-250-160 sound

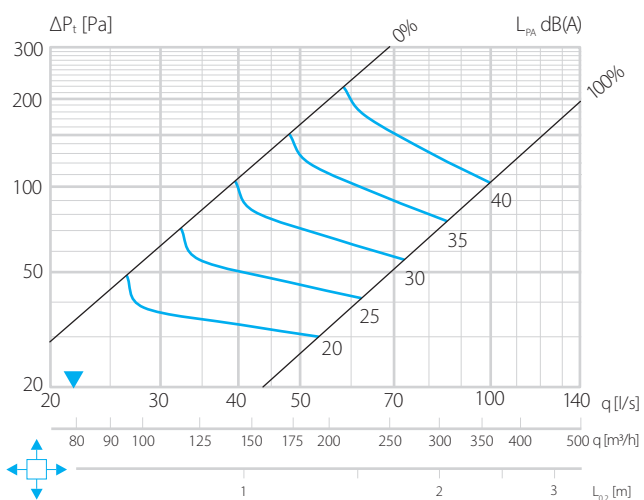

Diagram 06 - PLI-200 - TK-200-125 sound

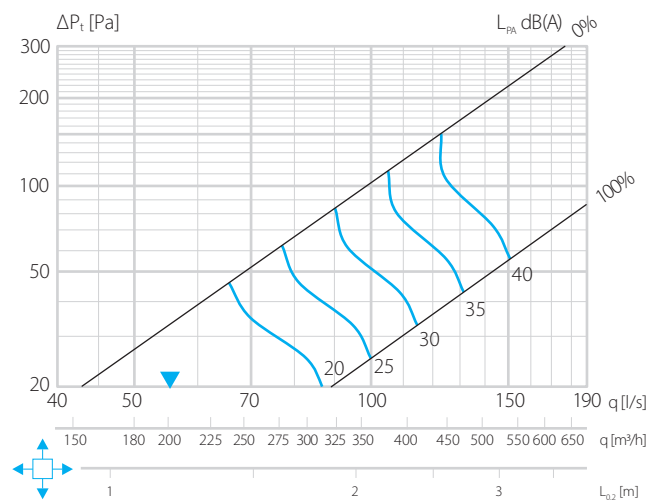

Diagram 09 - PLI-250 - TK-250-200 sound

Dimensions

Table 09 - Dimensions and weight - PLI

Size [mm]	Size [mm]				Weight [kg]
	B x B	ØD	C	F	
160		158	64	1	4,1
200	595x595	198	60	1	4,1
250		248	55	5	4,0

Hole dimensions = B x B + 5 mm

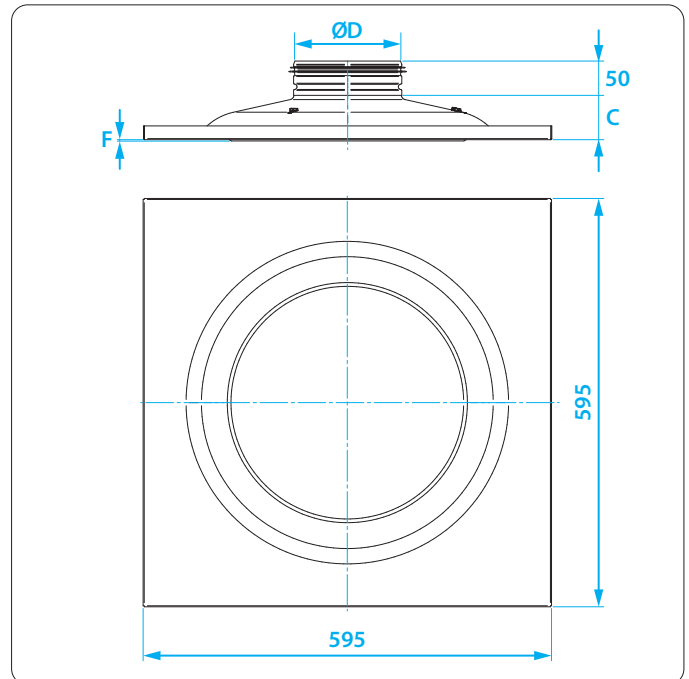

Figure 02 - Dimensions PLI

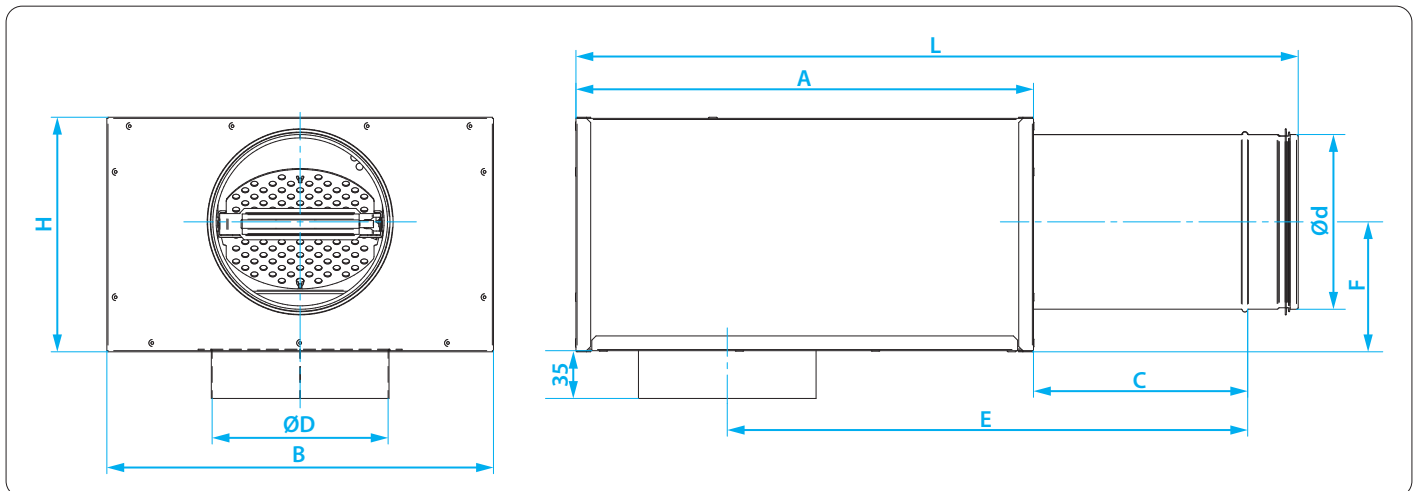

Figure 03 - Dimensions TK - 0-step type

Table 10 - TK commissioning box - 0-step type

Size	ØD*	Ød*	A	B	C	E	F	H	L	Weight [kg]
160-160	160	160	395	313	173	441	110	200	604	3,47
200-200	200	200	475	368	194	517	130	240	705	4,76
250-250	250	250	590	443	219	624	160	295	865	6,90

*Tolerance according to EN1506

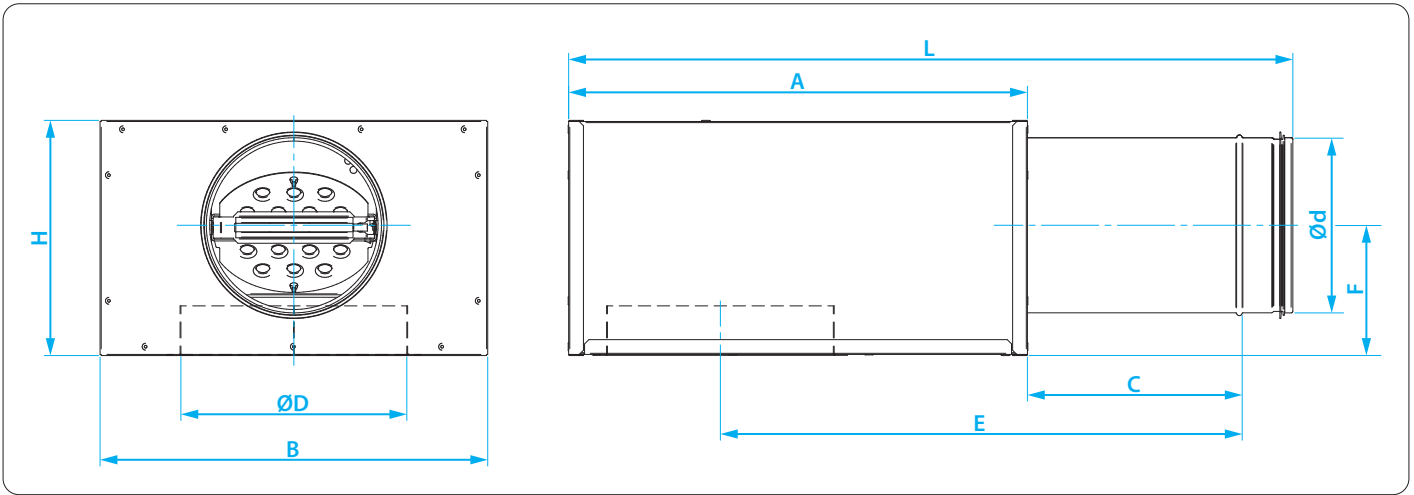

Figure 04 - Dimensions TK - 1-2 step type

Table 11 - TK commissioning box - 1-step type

Size	ØD*	Ød*	A	B	C	E	F	H	L	Weight [kg]
160-125	160	125	325	273	152	370	93	165	513	2,53
200-160	200	160	395	313	173	441	110	200	604	3,47
250-200	250	200	475	368	194	517	130	240	705	4,76

*Tolerance according to EN1506

Table 12 - TK commissioning box - 2-step type

Size	ØD*	Ød*	A	B	C	E	F	H	L	Weight [kg]
160-100	160	100	325	273	129	347	80	140	490	2,24
200-125	200	125	395	313	152	420	93	165	583	3,02
250-160	250	160	475	368	173	496	110	200	684	4,18

*Tolerance according to EN1506

Table 13 - Dimensions and weight - MN*

Size	Dimensions [mm]			Weight [kg]
	Muff side	Nipple side	Height	
160	160	158	110	0,44
200	200	198	110	0,55
250	250	248	79	0,55

*Adds 40 mm to the installation height.

Table 14 - Dimensions - PLI+TK

Size	Installation height with PLI + TK					
	0-step		1-step		2-step	
	TK [ØD-Ød]	U	TK [ØD-Ød]	U	TK [ØD-Ød]	U
160	160-160	299	160-125	229	160-100	204
200	200-200	335	200-160	260	200-125	225
250	250-250	385	250-200	295	250-160	255

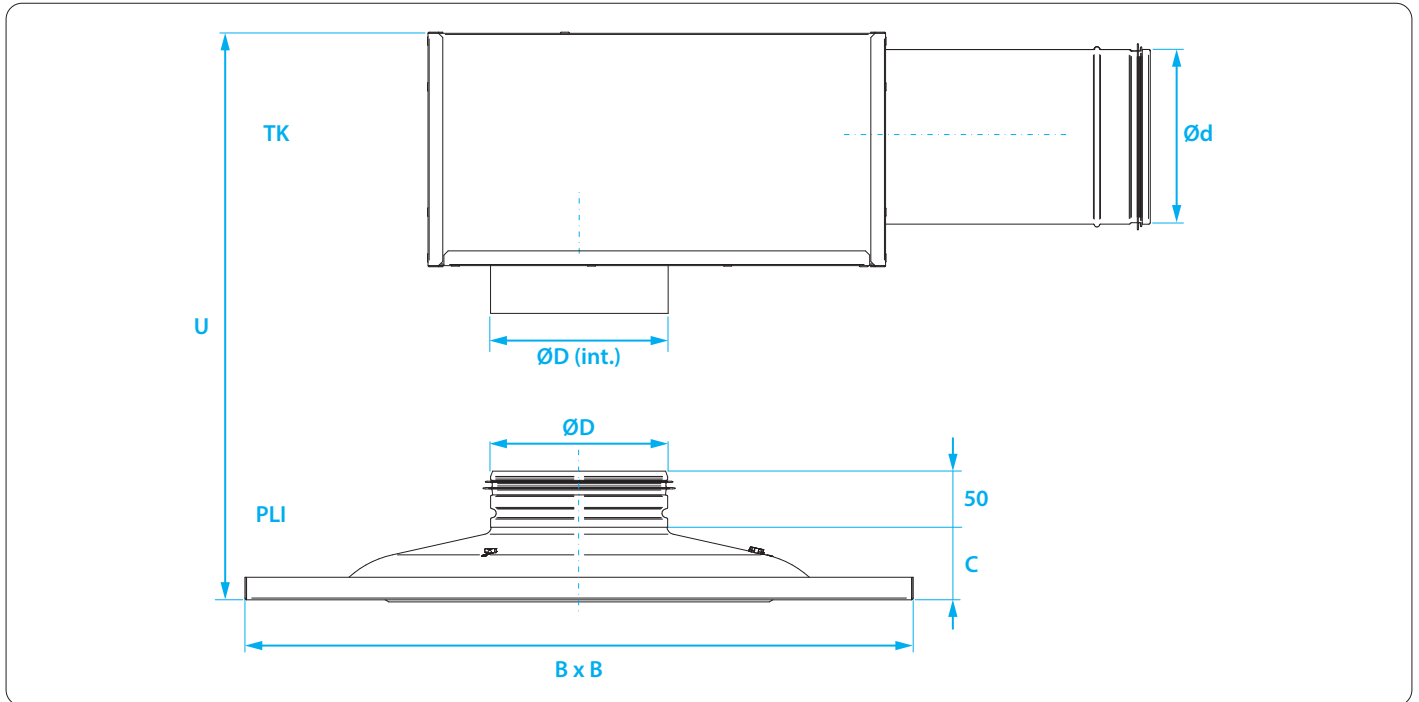

Figure 05 - Dimensions PLI + TK 0-step

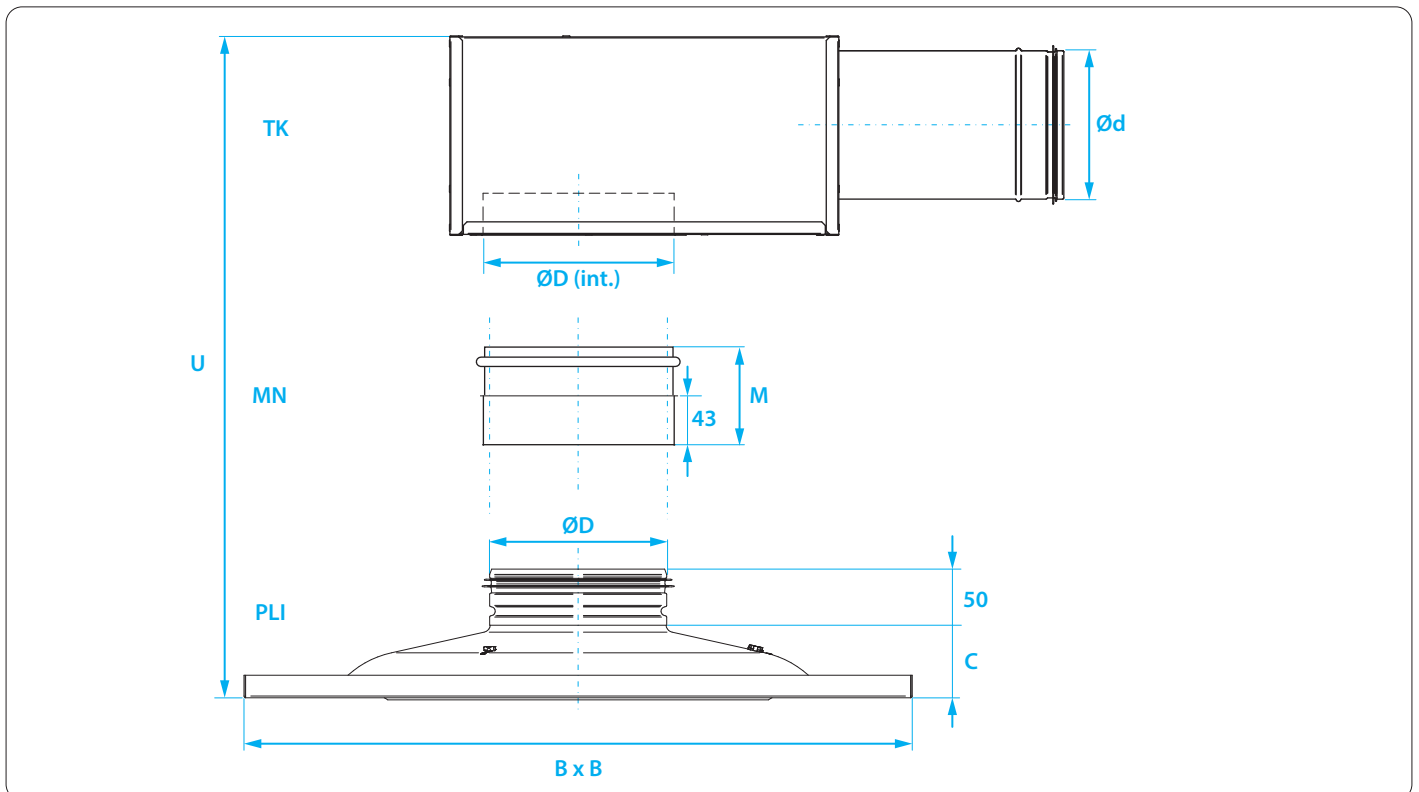

Figure 06 - Dimensions PLI + TK 1-2-step + MN

Ordering code

Table 15 - PLI ordering code

PLI	-XXX
Product acronym	Size [Ø]
Modular Ceiling Systems*	160
	200
	250
<i>Example: PLI-160</i>	

*Contact your nearest sales office if adaptation to other modular ceiling systems than standard T-grid T14/24 is needed.
 **MN is only relevant for installation in suspended ceilings when the diffuser is installed with a commissioning box.

Table 16 - TK ordering code

TK	-XXX-XXX
Product acronym	Commissioning box size
	0-step:
	160-160
	200-200
	250-250
	1-step:
	160-125
	200-160
	250-200
	2-step:
	160-100
	200-125
	250-160
<i>Example: TK-160-160</i>	